

HIGH-PERFORMANCE TRANSMITTER

LONG-TERM RELIABILITY

PX5500 Series

4 to 20 mA Output
0-15 to 0-10,000 psi
0-1 to 0-700 bar

1 bar = 14.5 psi
1 kg/cm² = 14.22 psi
1 atmosphere = 14.7 psi = 29.93 inHg = 760.2 mmHg = 1.014 bar

PX5500L1-100GI,
\$695, shown
smaller than
actual size.



All Ranges
\$695

- ✓ High 0.1% Accuracy
- ✓ Solid State Reliability
- ✓ Sputtered Strain Gage Design
- ✓ High Shock and Vibration Resistance
- ✓ Low Drift
- ✓ 5-Point NIST Calibration Standard

Applications

- ✓ Testing
- ✓ R&D/Engineering Test Laboratories
- ✓ Functional Test Systems
- ✓ Production Testing
- ✓ Product Quality Assurance
- ✓ Flight Testing
- ✓ Gas Turbine and Engine Test Standards
- ✓ Ground Support Equipment
- ✓ Hydraulic Systems
- ✓ Custody Transfer Measurements

OMEGA's PX5500 transducer series provides high performance in demanding industrial and research applications where accuracy, reliability, and price are important. These transducers have a 10-year MTBF rate and are stable to 0.1%

of FS over an 18-month period. This translates into less downtime, fewer test reruns, more time between calibrations, and more reliable pressure data. When recalibration is impossible, relying on the high stability of a PX5500 transducer may be the only cost-effective way to obtain pressure data over the long term. OMEGA's thin-film technology makes this

premium performance possible. The strain gages and associated structures are sputter-deposited directly onto the pressure sensing element, thus eliminating the need for adhesives. The resulting molecular bond between the sensing element and the strain gages ensures virtually no shifting, drifting, or "creep" in the performance of the transducer.

MOST POPULAR MODELS HIGHLIGHTED!

To Order (Specify Model Number)				
Models with 4 to 20 mA Output, MS33656-4 Connection, Integral Connector				
RANGE		MODEL NO.	PRICE	COMPATIBLE METERS*
Absolute Pressure (All Ranges Available in Absolute Pressure)				
0 to 15 psi	0 to 1.0 bar	PX5500L1-015AI	\$695	DP41-E, DP25B-E, DP24-E
0 to 25 psi	0 to 1.7 bar	PX5500L1-025AI	695	DP41-E, DP25B-E, DP24-E
0 to 50 psi	0 to 3.4 bar	PX5500L1-050AI	695	DP41-E, DP25B-E, DP24-E
0 to 100 psi	0 to 6.9 bar	PX5500L1-100AI	695	DP41-E, DP25B-E, DP24-E
Gage Pressure (All Ranges Also Available in Sealed Gage Pressure)				
0 to 15 psi	0 to 1.0 bar	PX5500L1-015GI	\$695	DP41-E, DP25B-E, DP24-E
0 to 25 psi	0 to 1.7 bar	PX5500L1-025GI	695	DP41-E, DP25B-E, DP24-E
0 to 50 psi	0 to 3.4 bar	PX5500L1-050GI	695	DP41-E, DP25B-E, DP24-E
0 to 100 psi	0 to 6.9 bar	PX5500L1-100GI	695	DP41-E, DP25B-E, DP24-E
0 to 250 psi	0 to 17.2 bar	PX5500L1-250GI	695	DP41-E, DP25B-E, DP24-E
0 to 500 psi	0 to 34.5 bar	PX5500L1-500GI	695	DP41-E, DP25B-E, DP24-E
0 to 1000 psi	0 to 68.9 bar	PX5500L1-1KGI	695	DP41-E, DP25B-E, DP24-E
0 to 1500 psi	0 to 103 bar	PX5500L1-1.5KGI	695	DP41-E, DP25B-E, DP24-E
0 to 2500 psi	0 to 172 bar	PX5500L1-2.5KGI	695	DP41-E, DP25B-E, DP24-E
0 to 3000 psi	0 to 207 bar	PX5500L1-3KGI	695	DP41-E, DP25B-E, DP24-E
0 to 5000 psi	0 to 345 bar	PX5500L1-5KGI	695	DP41-E, DP25B-E, DP24-E
0 to 10,000 psi	0 to 689 bar	PX5500L1-10KGI	695	DP41-E, DP25B-E, DP24-E

Comes with 5-point calibration.

* See section D for compatible meters.

Metric ranges available – consult Engineering.

To order absolute pressure models, change "G" in model number to "A" (no extra charge).

To order sealed gage models, change "G" in model number to "S" (no extra charge).

Ordering Examples: PX5500L1-1KSI, 1000 psi sealed gage transducer with 4 to 20 mA output, PTIH-10-6P, electrical connector and MS33656-4, male pressure port, \$695.

PTS06A-10-6S, mating connector (not included), \$47. PX5500L1-100AI, 100 psi absolute

pressure transducer with 4 to 20 mA output, PTIH-10-6P, electrical connector and MS33656-4, male pressure port, \$695. PTS06A-10-6S, mating connector (not included), \$47.

ACCESSORY

MODEL NO.	PRICE	DESCRIPTION
CE-1910	\$185	Reference Book: Applied Structural and Mechanical Vibrations

SPUTTERED SILICON TECHNOLOGY



CURRENT OUTPUT PRESSURE TRANSDUCERS

B

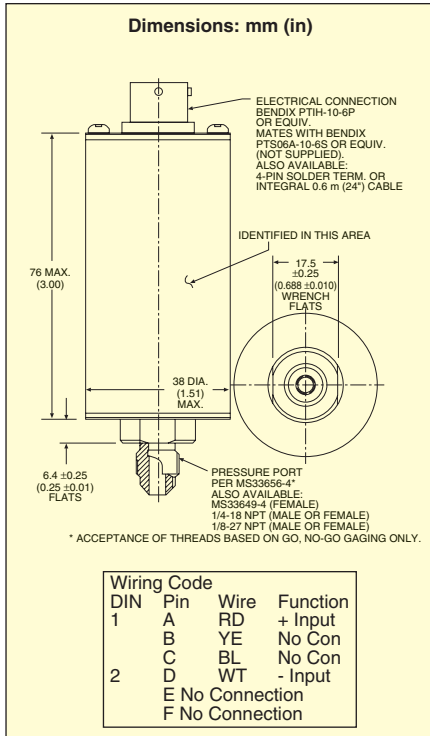

SPECIFICATIONS

mA Models

Excitation: 10 to 40 Vdc unregulated, reverse polarity protected

Output (FS): 4 to 20 mA ±0.8 mA adj

Zero Balance: 4 mA ±0.4 mA adj

Input Current: 20 mA max with no load

Load Impedance: 50 (V - 10) Ω max where V is supply voltage (40 Vdc max)

Insulation Resistance: 100 MΩ @ 45 Vdc between all pins shorted together and case

Electrostatic Discharge: Protected to 15 kV max

Sensing Element: 4-active-arm bridge using sputter-deposited thin-film elements

Accuracy (Combined Linearity, Hysteresis and Repeatability): ±0.10% FS (BFSL) <1000 psi ±0.15% FS 1000 psi and above

Vibration Sensitivity: At 20 g peak sinusoidal vibration from 10 Hz to 2000 Hz (½" D.A.), the output shall not exceed 0.04% FS/g for 15 psi range, decreasing to 0.003% FS/g for 1000 psi and above

Natural Frequency: 5 kHz for 15 psi, increasing logarithmically to 50 kHz for 5000 psi

Shock: Qualification level of 100 g, 11 ms half sine wave without damage

Operating Temp Range: -40 to 85°C (-40 to 185°F)

Compensated Temp Range: -18 to 82°C (0 to 180°F)

Thermal Effects (Over the Compensated Range):

Span: ±0.02% FS/°F

Zero: ±0.02% FS/°F

Proof Pressure: 2 times rated pressure or 15,000 psi, whichever is less, will not cause changes in performance beyond the specified tolerance

Burst Pressure: 3 times rated pressure or 20,000 psi, whichever is less, will not cause rupture of the pressure containment cavity

Wetted Parts: 17-4 PH or 15-5 PH stainless steel

Electrical Connection: PTIH-10-6P (see Custom Configurations)

Pressure Port: MS33656-4 (male) (see Custom Configurations)

Optional: MS33649-4, ¼-18 NPT male/female, ¼-27 NPT male/female

Mating Connector: PTS06A-10-6S (not included)

Weight: 225 g (8 oz) maximum

The micro-geometry design of the PX5500 sensing element results in a very small, low-mass sensor that reduces effects of mechanical vibration and shock. The PX5500 delivers accuracy, reliability, and stability at competitive prices.

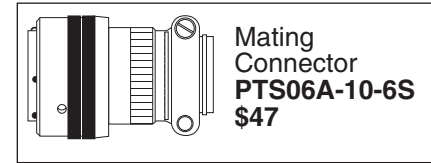

CUSTOM CONFIGURATIONS

SERIES	PRESSURE PORT	ELECTRICAL CONNECTION	RANGE	UNITS	OUTPUT	OPTIONS
PX5500	[1]	[2]	[3]	[4]	[5]	[6]
	A = ¼-27 NPT male		015 psi	A, G, S	V = mV/V \$550	CAL11 = 11-pt cal
	B = ¼-27 NPT female		025	A, G, S	5T = 0 to 5V \$695	+ \$250
	C = ¼-18 NPT male		050	A, G, S	I = 4 to 20 mA	
	D = ¼-18 NPT female		100	A, G, S	\$695	
	L = MS33656-4		250	A, G, S		
	M = MS33649-4		500	A, G, S		
			1K	A, G, S		
			1.5K	A, G, S		
			2.5K	A, G, S		
			3K	A, G, S		
			5K	A, G, S		
			10K	A, G, S		
		0 = 0.6 m (2') cable \$2/ft over 0.6 m (2')				
		1 = PTIH-10-6P connector (or equal, no charge). Mating connector (not included), order PTS06A-10-6S \$47.				
		3 = 4-pin eyelet header				
		6 = DIN connector				

To order a custom configuration:

1. Select a pressure port
2. Select electrical connection
3. Select a pressure range
4. Select pressure units
5. Select output
6. Select options and agency approvals

Comes with 5-point calibration.

Metric ranges available – consult Engineering.

Ordering Examples: PX5500A1-015AV, ¼-27 NPT male pressure port, Bendix style connector, 15 psi absolute pressure range and mV/V output, \$550. PTS06A-10-6S, mating connector (not included), \$47. PX5500M1-10KG5T, MS33649-4 female pressure port, Bendix style connector, 10,000 psi gage pressure range and 0 to 5 Vdc output, \$695. PTS06A-10-6S, mating connector (not included), \$47. PX5500L0-015A1-25FT, MS33656-4 male pressure port, 8 m (25') lead wire, 15 psi absolute pressure range and 4 to 20mA output, \$695 + 46 = \$741.