

SUBMERSIBLE PRESSURE TRANSMITTER FOR LEVEL AND DEPTH MEASUREMENT 38 mm (1.5") DIA.

PX78 Series
4-20 mA Output
0-4 to 0-15 psi
0-350 mbar to 0-1 bar

Starts at
\$725



- ✓ All Stainless Steel Housing
- ✓ Hermetically Sealed
- ✓ Protective Cap Included
- ✓ 15 m (50') Vented Cable Standard

OMEGA's PX78 is a submersible transmitter suitable for liquid level and depth measurement. Its all stainless steel, hermetically sealed housing makes it suitable for immersion in most industrial liquids and oils. A 15 m (50') vented cable (longer lengths available) provides an atmospheric pressure reference.

SPECIFICATIONS

Excitation: 10 to 40 Vdc

Output: 4 to 20 mA ±10%

Max Loop Resistance:
(Input voltage - 10) x 50

Zero Balance: 4 mA ±0.5%

Accuracy: 0.5% linearity, hysteresis and repeatability combined

Operating Temp Range:
-29 to 93°C (-20 to 200°F)

Compensated Temp Range:
16 to 71°C (60 to 160°F)

Thermal Effects:

Span: 0.003% rdg/°F
Zero: 0.005% FSO/°F

Proof Pressure:

150% of rated pressure

Burst Pressure:

300% of rated pressure

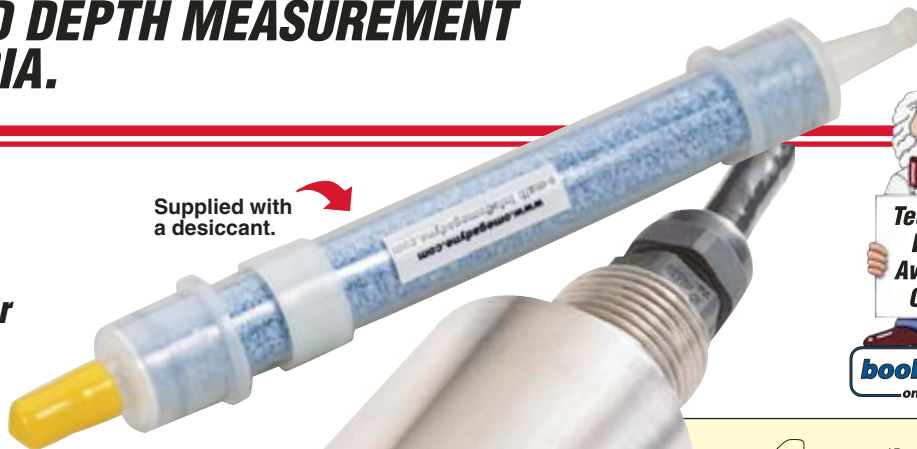

Supplied with a desiccant.



PX78U7-005GI, \$725, shown smaller than actual size.

Wetted Parts:

316 stainless steel diaphragm
17-4 stainless steel housing

Pressure Port: Nose protector included

Electrical Connection:
15 m (50') PVC-insulated shielded and vented cable

Notice: OMEGA does not offer a warranty on this product, its use, or application. It is the end user's responsibility to assure proper installation and use of this transmitter.

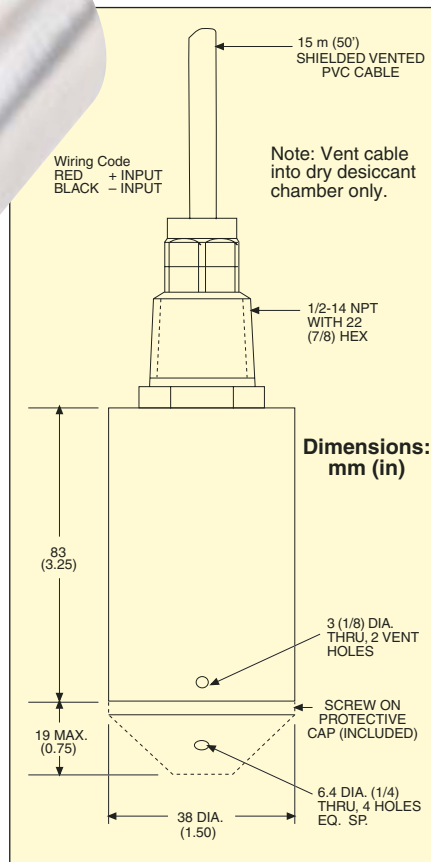

MOST POPULAR MODELS HIGHLIGHTED!

To Order (Specify Model Number) 15 m (50') Cable Standard

RANGE	MODEL NO.	PRICE	COMPATIBLE METERS*
0 to 4 psig	0 to 0.27 bar	PX78U7-004GI	\$725 DP41-E, DP25B-E, DP24-E
0 to 5 psig	0 to 0.34 bar	PX78U7-005GI	725 DP41-E, DP25B-E, DP24-E
0 to 10 psig	0 to 0.69 bar	PX78U7-010GI	725 DP41-E, DP25B-E, DP24-E
0 to 15 psig	0 to 1.0 bar	PX78U7-015GI	725 DP41-E, DP25B-E, DP24-E

Comes with complete operator's manual.

Metric ranges available - consult Engineering.

* See section D for compatible meters.

To order with extra cable, add suffix "-(Length in feet)FT" and **\$2.50/ft** beyond standard 15 m (50') length.

Ordering Examples: PX78U7-015GI-100FT, 15 psi transmitter with 4 to 20 mA output and 30 m (100') vented cable, \$725 + (50 x 2.50) = **\$850**. PX78U7-005GI, 5 psi gage pressure transmitter with 4 to 20 mA output and standard 15 m (50') of vented cable, **\$725**.

ACCESSORIES

MODEL NO.	PRICE	DESCRIPTION
A019385	\$35	Replacement desiccant
PE-1022	79	Reference Book: Process Control System